

INSTALLATION AND REPLACEMENT INSTRUCTIONS FOR DISC SPRINGS IN ULTRA® 2" C, 3½" D, AND 4½" E STATION PUNCH GUIDES

THICK TURRET ULTRA® C, D AND E STATION DISC SPRING INSTALLATION AND REPLACEMENT FIXTURE ASSEMBLY:

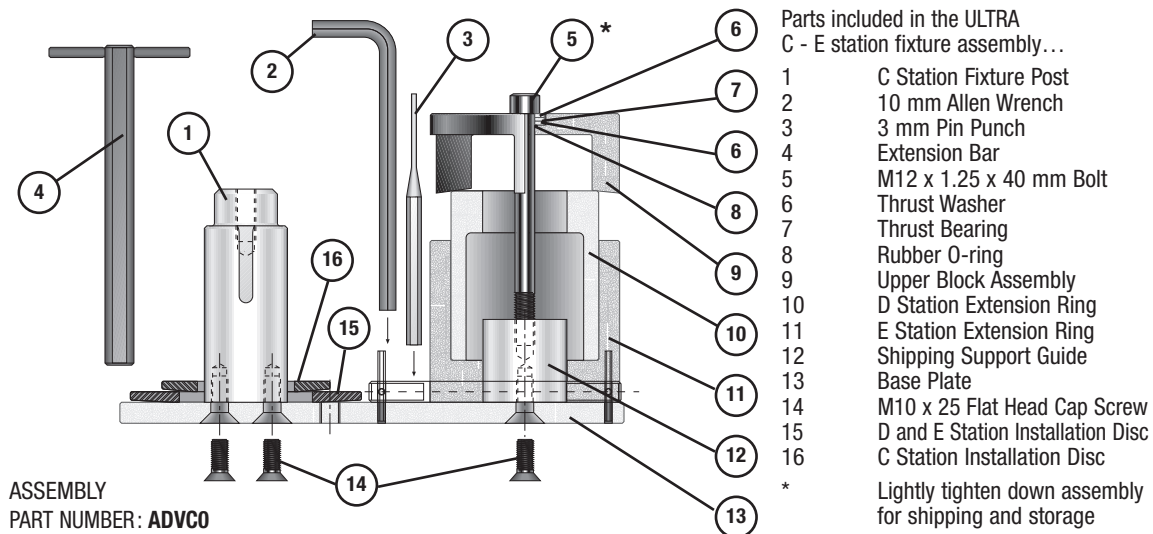

THICK TURRET ULTRA® C, D AND E STATION DISC SPRING INSTALLATION AND REPLACEMENT INSTRUCTIONS :

FIG. 1

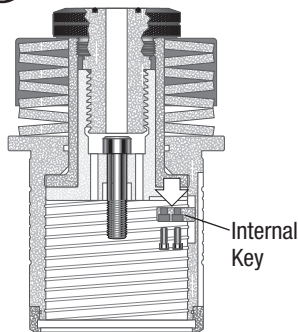

1. Remove punch and stripper from punch guide.

2. **Fig. 1.** Remove internal key from D and E station punch driver by removing two M5 cap screws with a 4 mm allen wrench.

2A. Do not remove the internal key from the C station punch holder.

3. **Fig. 2.** Insert punch driver extension bar (4) into ULTRA holder and hand tighten

FIG. 2

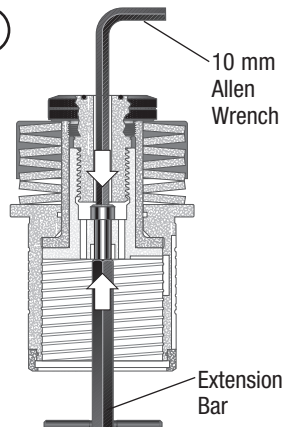

onto M12 draw bolt. Finish tightening the M12 draw bolt to the punch driver extension bar using a 10 mm allen wrench (2). The punch driver extension bar should now be securely attached to the punch driver.

4. **Fig. 3.** Turn the punch driver extension bar COUNTERCLOCKWISE. Unthread and separate the punch driver from the ULTRA holder.

4A. For C station punch holder: turn the

FIG. 3

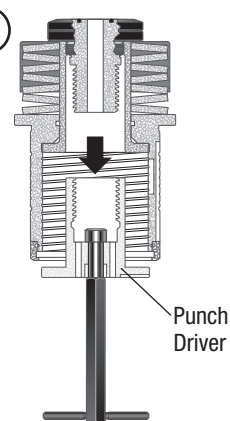

punch driver extension bar COUNTERCLOCKWISE. Unthread and separate punch driver from the ULTRA holder until punch driver nears the internal key. Align slot in punch driver with the internal key. Hold in the punch head button and rotate punch head COUNTERCLOCKWISE until punch driver flange is past the internal key. Continue to turn punch driver extension bar until punch driver is free of the punch holder.

NOTE: Punches should be tightened to
75 lbs. ft. (102 N • m)

MAINTENANCE FIXTURE